



50Ω TERMINATED 18 GHz SMA LATCHING S.P.4 T. SWITCH

OPTIONS: INDICATOR / SELF CUT-OFF / TTL DRIVE / SUPP. DIODES

R F CHARACTERISTICS

NUMBER OF WAYS : 4
 FREQUENCY RANGE : 0 - 18 GHz
 IMPEDANCE : 50 Ohms

| | | | | |
|-----------------|---------|---------|----------|-----------|
| FREQUENCY (GHz) | 0 - 3 | 3 - 8 | 8 - 12.4 | 12.4 - 18 |
| V.S.W.R <= | 1.20 | 1.30 | 1.40 | 1.50 |
| INSERT. LOSS <= | 0.20 dB | 0.30 dB | 0.40 dB | 0.50 dB |
| ISOLATION >= | 80 dB | 70 dB | 60 dB | 60 dB |
| AVER. POWER (*) | 240 W | 150 W | 120 W | 100 W |

TERMINATION IMPEDANCE : 50 Ohms
 TERMINATION AVG. POWER AT 25° C : 1 W per termination
 3 W total power

ELECTRICAL CHARACTERISTICS

ACTUATOR : LATCHING
 NOMINAL CURRENT AT 25° C (*10%) : 125 mA / RESET : 500 mA
 ACTUATOR VOLTAGE (Vcc) : 28V (24 to 30V) / NEGATIVE COMMON
 TERMINALS : 25 pins D-SUB male connector
 INDICATOR RATING : 1 W / 30 V / 100 mA
 SELF CUT-OFF TIME : 40 ms < CT < 120 ms
 TTL INPUTS (E) - High level : 2.2 to 5.5V / 800µA at 5V
 - Low level : 0 to 0.8V / 20µA at 0.8V

MECHANICAL CHARACTERISTICS

CONNECTORS : SMA female per MIL-C 39012
 LIFE : 2.000.000 cycles per position
 SWITCHING TIME (nominal voltage; 25° C) : < 15 ms
 CONSTRUCTION : splashproof
 WEIGHT : < 250 g

ENVIRONMENTAL CHARACTERISTICS

OPERATING TEMPERATURE RANGE (°C) : -40 , +85
 STORAGE TEMPERATURE RANGE (°C) : -55 , +85

(* : average power at 25° C per RF path)

This information is given as an indication. In the continual goal to improve our products, we reserve the right to make any modifications judged necessary

4112-9212

DRAWING

General tolerance: ± 0,5 mm

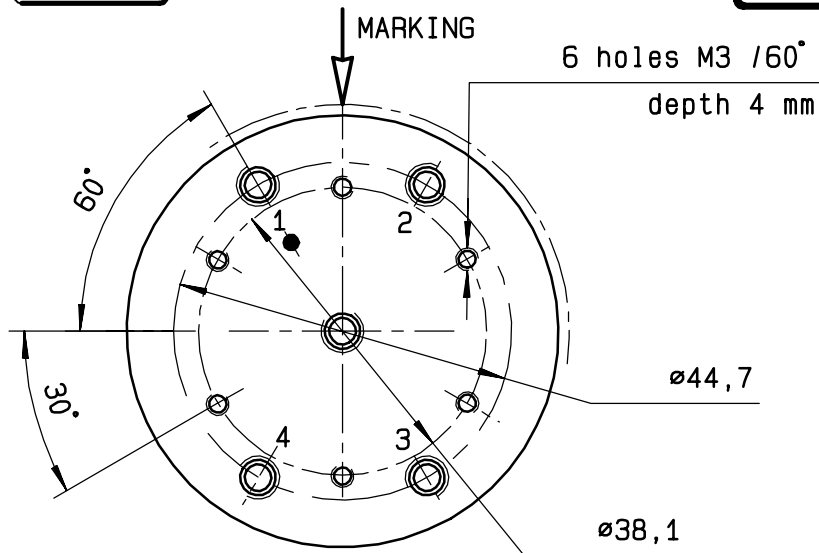

| TTL input | RF continuity | Ind. |
|-----------|----------------|------|
| RESET = 1 | All ports open | -- |
| E1 = 1 | IN ↔ 1 | D.E |
| E2 = 1 | IN ↔ 2 | D.F |
| E3 = 1 | IN ↔ 3 | D.G |
| E4 = 1 | IN ↔ 4 | D.H |

4-40 UNC 25 pins D-SUB male connector

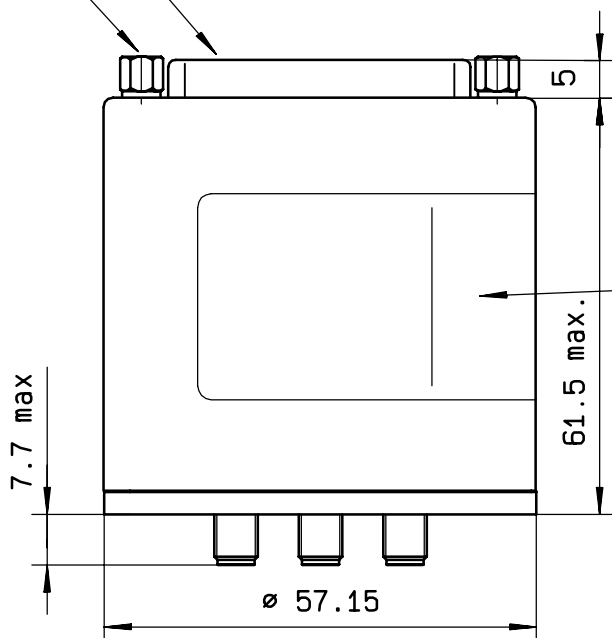

MARKING TOP VIEW (TERMINALS)

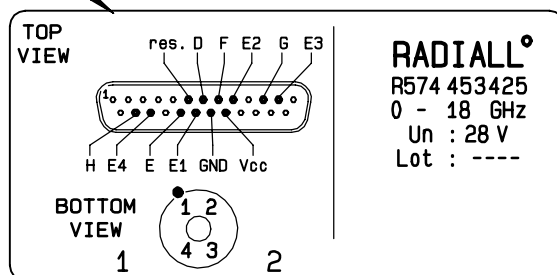

RADIALL
 R574 453 425
 0 - 18 GHz
 Un : 28 V
 Lot : ----

SCHEMATIC DIAGRAM

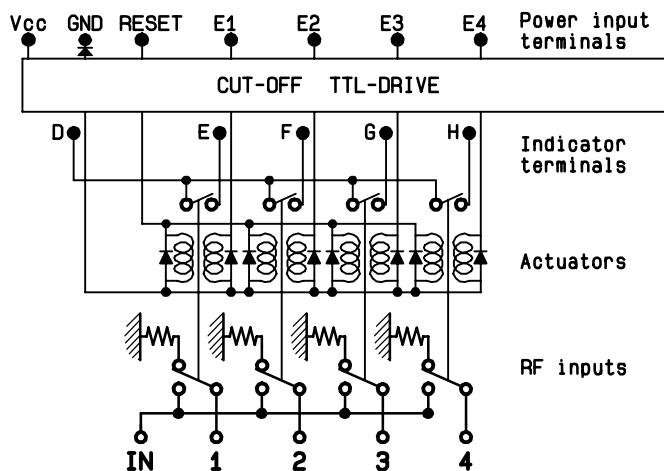

This information is given as an indication. In the continual goal to improve our products, we reserve the right to make any modifications judged necessary

4113-9212